

# Directly actuated seat valves

2/2- and 3/2-way

## Features

- Directly actuated directional seat valve controlling pressurised media.
- The valve seat seals hermetically preventing internal leaks.
- All parts are made of corrosion-resistant materials, and they are easily replaceable.
- Valve design in a structural plate form
- On request, the valve can be equipped with other actuations than the electromagnet, e.g. hydraulic or pneumatic cylinder actuation, manual pushbutton operation
- In addition, the individual actuations can be supplemented with a maintained-contact function

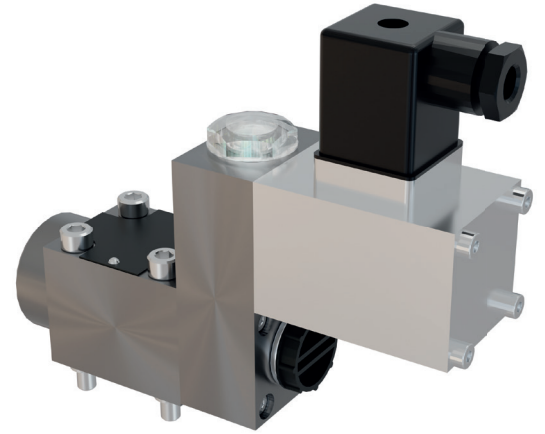

## Function of 2/2-way valve

The force (1), generated by the actuation, acts through the lever (2), the tappet (3) on the ball (4) and presses it out of the valve seat (5). This is used to connect lines P and A, see Example. The ring (6) supports the flange seal from the inside. The volume flow is limited by the entire flow resistance.

Depending on the arrangement of the valve seat (5) and ball (4) the valve will have the basic position normally closed (NC) or normally open (NO).

### Example 2/2-way valve

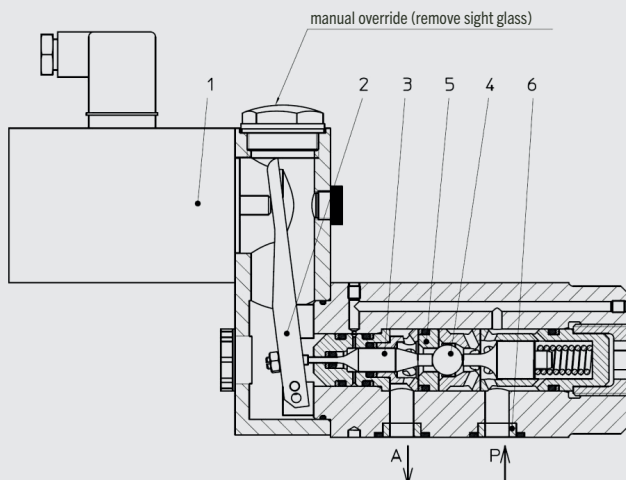

#### Symbol



## Function of 3/2-way valve

The force (1), generated by the actuation, acts through the lever (2), the tappet (3) on the ball(s) (4) and presses it out of the right valve seat (5) and into the left valve seat (5). This is used to connect lines P and A and shut off line T, see Example. The ring (6) supports the flange seal from the inside. The volume flow is limited by the entire flow resistance.

The 3/2-way valve is provided with a „negative overlap“. During the changeover process, connections P, A and T are briefly connected with each other. The changeover occurs so fast that the hydraulic effects are negligible. By design, a 3/2-way valve always requires the connection of a T-connector; only then a proper switching function can be ensured.

Depending on the design of the valve insert a valve with the basic position „A→T NO“ (lines A and T are connected) or „P→A NO“ (lines P and A are connected) is provided.

### Example 3/2-way valve

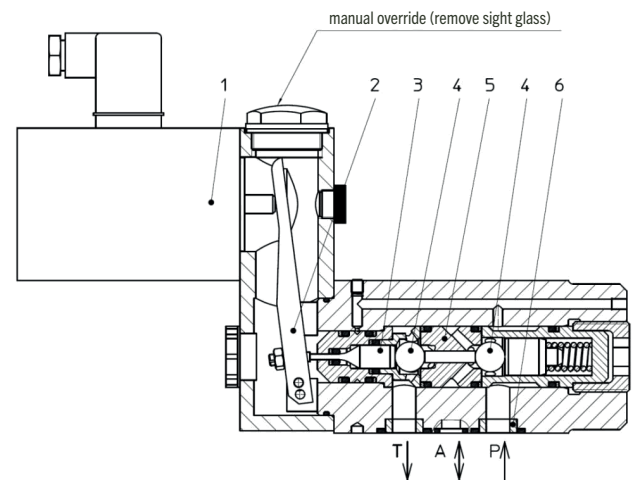

#### Symbol



# Directly actuated seat valves DN6 | PN100 | 30l/min

2/2- and 3/2-ways

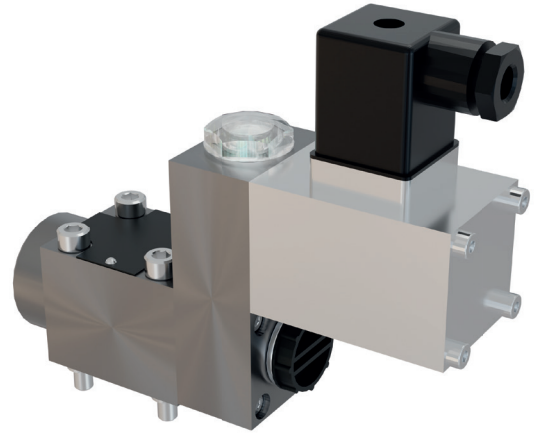

## Technical data

measured with HFA medium 97/3%, at 20°C

General	
Weight	3,5 kg
Installation position	any
Ambient temperature	-10 to 50°C (hydraulic fluids, heed standard requirements)
Material Valve parts	Stainless steel, bronze except electromagnet
Material Seals	NBR, PTFE
Hydraulic	
max. operating pressure of connector P	100bar
max. operating pressure of connector A	100bar
max. operating pressure of connector T	50bar
max./min. control pressure of connector Z	see Order information
max. volume flow P→A	30 l/min
max. volume flow A→T	30 l/min
specified direction of flow	P→A, A→T
Pressure fluid	water, HFA
- Medium - Temperature range	5 to 50°C
- Medium - Quality	see Hauhinco requirements on water and HFA media
- Cleanliness class, filter fineness	class 20/18/15, filter fineness 25µm
- Viscosity	0,6 bis 100 mm <sup>2</sup> /s
Pressure fluid	mineral oil, HLP
- Medium - Temperature range	-10 to 50°C acc.
- Medium - Quality	to DIN 51524
- Cleanliness class, filter fineness	Class 20/18/15, filter fineness 25µm
- Viscosity	0,6 bis 100 mm <sup>2</sup> /s
Use of other pressure fluids on request.	
Electric	
Voltage	24 VDC, 110 VAC (96 VDC), 230 VAC (205 VDC)
AC grid, admissible tolerance	± 10%
AC grid, admissible frequency	50 to 60 Hz
Power consumption	36 W
Operating time	100% ED
Degree of protection acc. to EN60529	IP65
max. switching rate	1 Hz

## Order information

### Included in the scope of supply

Mounting screws of the valve	Cheese-head screw M8
Cable socket of the valve solenoid - Supply voltage 24 VDC - Supply voltage 110 VAC - Supply voltage 230 VAC	according to DIN 43650 – type of design A max. 100 VA, LED-display + Z-diode, IP65 max. 1.5 A, bridge rectifier, LED display, IP65 max. 1.5 A, bridge rectifier, LED display, IP65

### 2/2-way valve DN3 | PN100 | 30l/min, solenoid actuation

Designation	Basic position	Voltage	Article number
2/2-way valve DN6 PN100	NC	24 VDC	on request
	NC	110 VAC	on request
	NC	230 VAC	on request
2/2-way valve DN6 PN100	NO	24 VDC	on request
	NO	110 VAC	on request
	NO	230 VAC	on request

### 3/2-way valve DN3 | PN100 | 30l/min, solenoid actuation

Designation	Basic position	Voltage	Article number
3/2-way valve DN6 PN100	A→T NO	24 VDC	6576230
	A→T NO	110 VAC	on request
	A→T NO	230 VAC	on request
3/2-way valve DN6 PN100	P→A NO	24 VDC	6576249
	P→A NO	110 VAC	on request
	P→A NO	230 VAC	on request

# 2/2-way valve DN6 | PN100 | 30l/min, solenoid actuation

## Dimensions

## Symbol

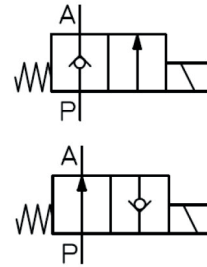
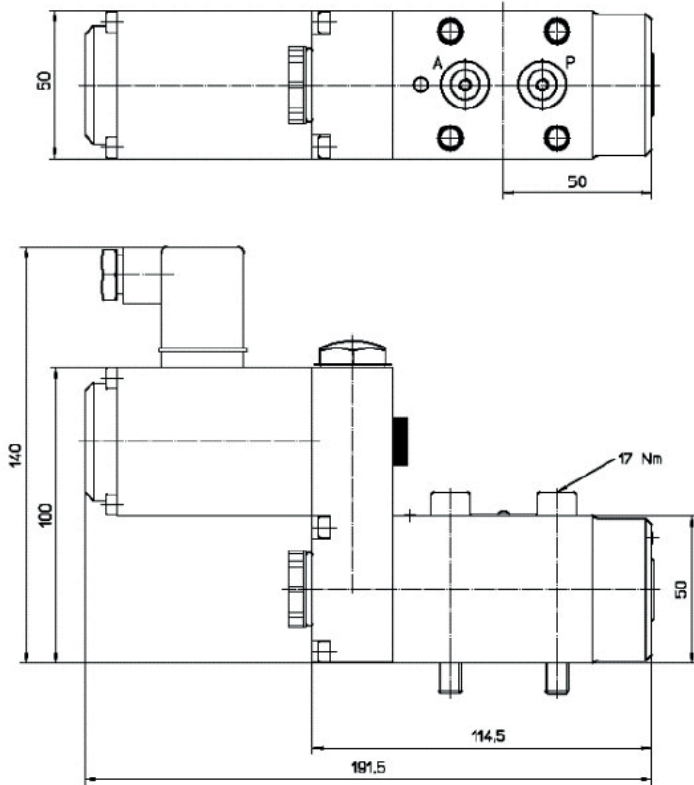

## Connection diagram

## $\Delta p - qV$ characteristic curve

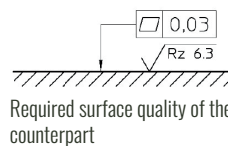
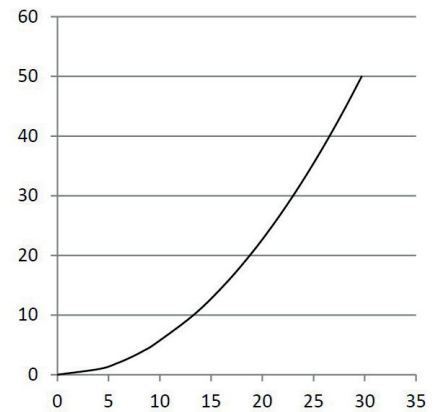
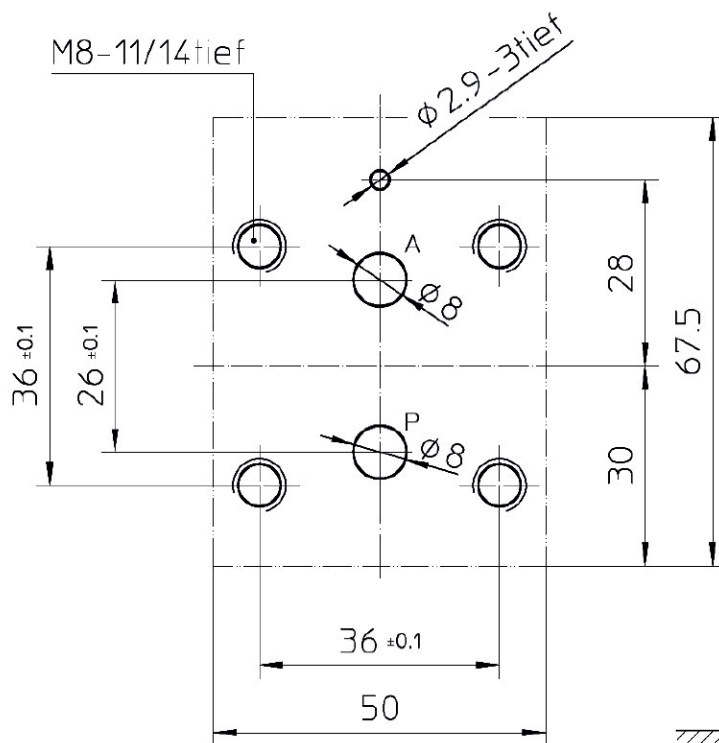

# 3/2-way valve DN6 | PN100 | 30l/min, solenoid actuation

## Dimensions

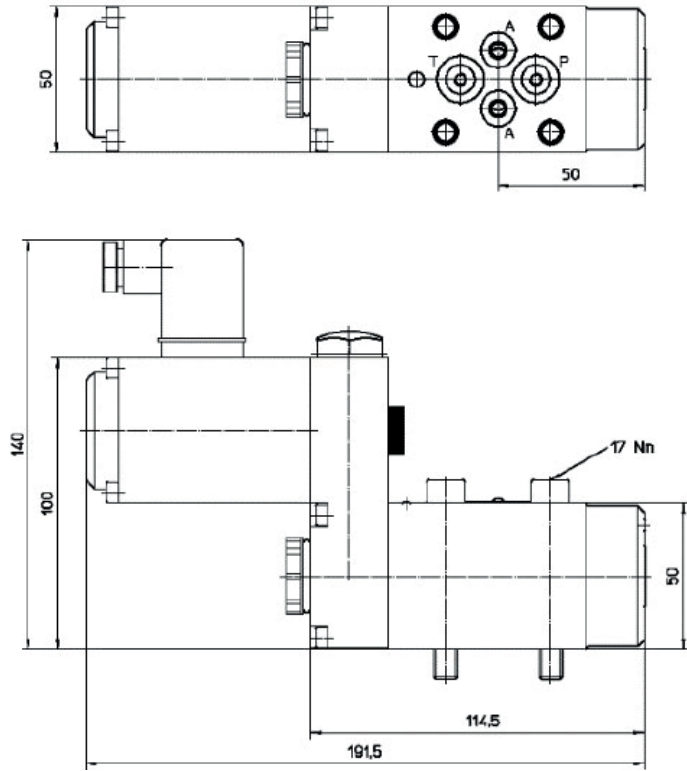

## Symbol

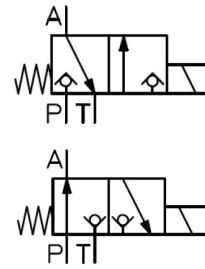

## Connection diagram

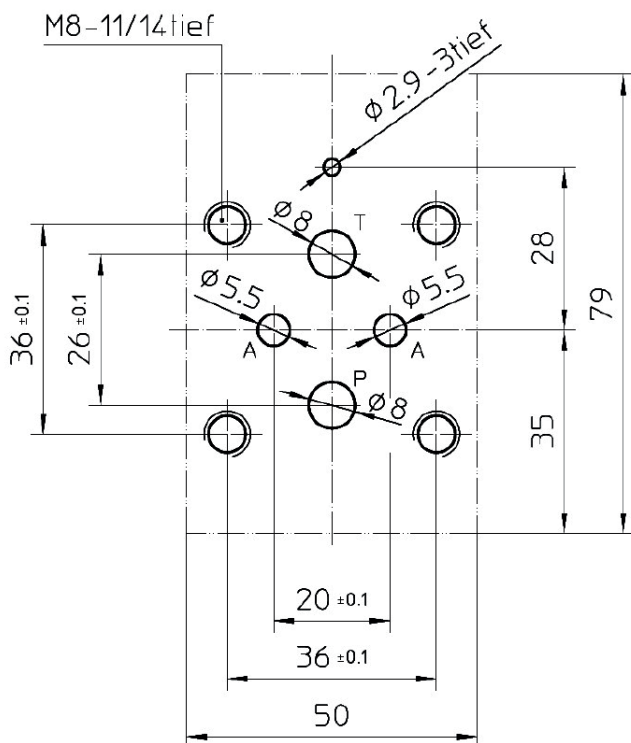

## $\Delta p - qV$ characteristic curve

